

USN

--	--	--	--	--	--	--	--	--	--

18AU63

## Sixth Semester B.E. Degree Examination, June/July 2023 Design of Machine Elements – II

Time: 3 hrs.

Max. Marks: 100

*Note: Answer any FIVE full questions, choosing ONE full question from each module.*

### Module-1

- 1 a. Give the difference between a straight and curved beam. (05 Marks)  
 b. Determine the value of stem thickness 't' in the T-cross section of a curved beam shown in Fig. Q1 (b). Such that the normal stresses due to bending at the extreme inner and outer fibres are numerically equal.

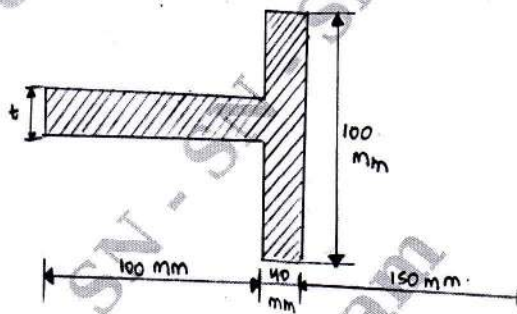

Fig. Q1 (b)

(15 Marks)

OR

- 2 a. Derive an expression for the stress induced in a helical spring with usual notations. (06 Marks)  
 b. A semi elliptical laminated spring with two full length leaves and ten graduated leaves is supported at two points 1000 mm apart. The central load acting on spring is 6 kN and the central band width is 100 mm. The ratio of total depth of the spring to its width is 2.5 the design stress of the material is 400 MPa. Determine the width and thickness of the leaves which are initially stressed. Also find the initial gap. Take  $E = 208 \text{ GPa}$  and determine the deflection. (14 Marks)

### Module-2

- 3 a. Derive a lewis equation for the beam strength of gear tooth. (06 Marks)  
 b. A 12 kW motor running at 1770 rpm drives a fan through a pair of spur gears (forged steel SAE 1030 pinion and CI gear). With a reduction ratio of 3.9 : 1. Design the gear and check for dynamic and wear load. (14 Marks)

OR

- 4 Design a pair of  $20^\circ$  stub teeth helical gears to transmit 34 kW at 2800 rpm the speed ratio is 4.5 and number of teeth on pinion are 18 the diameter of pinion is limited to 125 mm helix angle  $25^\circ$ . Check dynamic and wear loads. Material for both pinion and gears are same. ( $\sigma_d = 230 \text{ MPa}$ ). (20 Marks)

Important Note : 1. On completing your answers, compulsorily draw diagonal cross lines on the remaining blank pages.  
 2. Any revealing of identification, appeal to evaluator and /or equations written eg. 42+8 = 50, will be treated as malpractice.

**Module-3**

- 5 A pair of straight level gears at right angles is to transmit 5 kW at 1200 rpm of the pinion. The diameter of the pinion is 80 mm and the velocity ratio is 3.5 the tooth form is  $14.5^\circ$ . Both the pinion and gears are made up of CI. With allowable stress of 55 MPa. Design the bevel gear and check for dynamic and wear loads. (20 Marks)

OR

- 6 Design a worm gear drive for a speed reduction ratio of 25. The worm is made up of C30 heat treated steel and worm wheel is made up of phosphor bronze. The pinion rotates at 600 rpm and transmits 35 kW. Also calculate the heat dissipation through the drive. (20 Marks)

**Module-4**

- 7 a. List different types of mechanical brakes. (05 Marks)  
 b. A simple band brake as shown in Fig. Q7 (b) is to be designed to absorb a power of 30 kW at 750 rpm. Determine.  
 (i) The effort required to stop clockwise rotation of the brake drum and counter clockwise also. Assuming  $f = 0.25$ .  
 (ii) The dimensions of the rectangular cross section of the brake lever assuming its depth to be twice thickness.

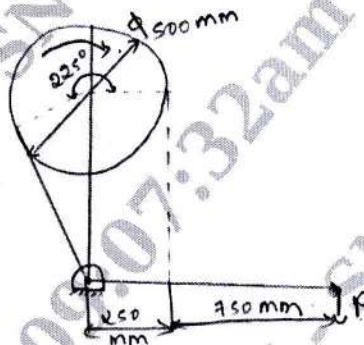

Fig. Q7 (b)

(15 Marks)

OR

- 8 a. A multiple clutch as steel on bronze is to transmit 8 kW at 1440 rpm. The inner diameter of the contact is 8 mm and the outer diameter of the contact is 1400 mm. The clutch operates in oil with a co-efficient of friction of 0.1. The average pressure is 0.35 MPa. Assuming uniform wear and determine  
 (i) Number of steel and bronze plates.  
 (ii) Axial force required.  
 (iii) Actual maximum pressure. (12 Marks)  
 b. Derive an expression for frictional torque in disc clutch, assuming uniform wear theory. (08 Marks)

**Module-5**

- 9 a. Derive Rettroff's equation for a lightly loaded bearing. (05 Marks)  
 b. Design a journal bearing for a centrifugal pump running at 1200 rpm. Diameter of journal is 100 mm and load on bearing is 15 kN. Take  $\frac{l}{d} = 1.5$  bearing temperature  $50^\circ$  and ambient temperature  $30^\circ$ . Find whether artificial cooling is need. (15 Marks)

OR

- 10 a. Discuss the advantages and disadvantages of ball and roller bearing over journal bearing. (06 Marks)
- b. A deep groove ball bearing is used for an axial flow compressor to carry a radial load 2.5 kN and axial load of 1.5 kN. The service imposes light shock with shock factor 1.5 the bearing is to be used 40 hours per week for 5 days. The speed of the shaft is 1000 rpm and shaft diameter is 60 mm. Select a suitable ball bearing. (14 Marks)

\*\*\*\*\*